

SILICON BRIDGE RECTIFIERS

Features

- ◆ Glass Passivated Chip Junction
- ◆ Rating to 1000V PRV
- ◆ Ideal for printed circuit board
- ◆ Reliable low cost construction utilizing molded plastic
- ◆ technique Plastic material has U/L lammability classification 94V-0
- ◆ Low forward voltage drop,high current capability

Mechanical Data

Case : JEDEC GBJ Molded plastic body

Terminals : Solder plated, solderable per MIL-STD-750,Method 2026

Polarity : Polarity symbol marking on body

Mounting Position : Any

Mounting Torque: 5in-lbs

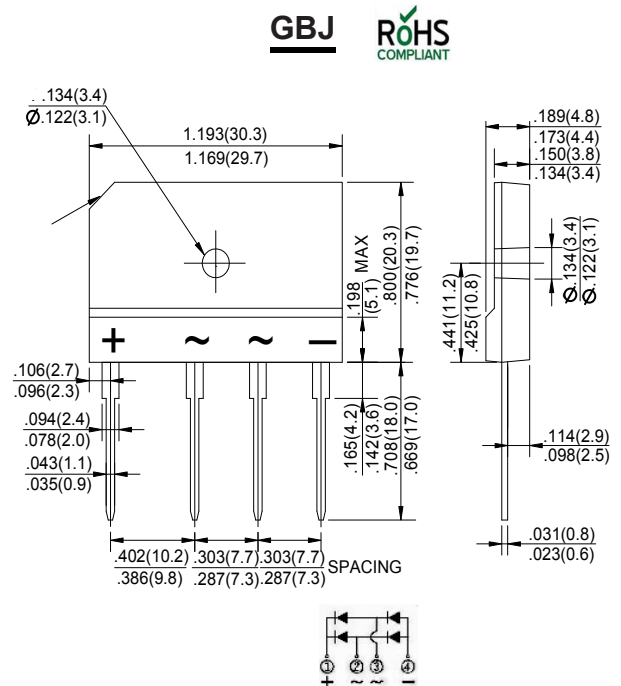

Dimensions in inches and (millimeters)

Maximum Ratings And Electrical Characteristics

Ratings at 25°C ambient temperature unless otherwise specified.

Single phase half-wave 60Hz, resistive or inductive load, for capacitive load current derate by 20%.

Parameter	SYMBOLS	MDD	MDD	MDD	MDD	MDD	MDD	MDD	UNITS
		GBJ35005	GBJ3501	GBJ3502	GBJ3504	GBJ3506	GBJ3508	GBJ3510	
Marking Code									
Maximum repetitive peak reverse voltage	V_{RRM}	50	100	200	400	600	800	1000	V
Maximum RMS voltage	V_{RMS}	35	70	140	280	420	560	700	V
Maximum DC blocking voltage	V_{DC}	50	100	200	400	600	800	1000	V
Maximum average forward (with heatsink Note 2) Rectified current @ $T_c = 100^\circ\text{C}$ (without heatsink)	I_{AV}				35.0				A
Peak forward surge current 8.3ms single half sine-wave superimposed on rated load (JEDEC Method)	I_{FSM}				400				A
Rating for Fusing ($t < 8.3\text{ms}$)	I^2t				510				A ² s
Maximum forward voltage at 17.5A DC	V_F				1.1				V
Maximum DC reverse current $T_A = 25^\circ\text{C}$ at rated DC blocking voltage $T_A = 125^\circ\text{C}$	I_R				10				μA
					0.5				mA
Typical Junction Capacitance (Note 1)	C_J				85				pF
Typical Thermal Resistance (Note 2)	$R_{\theta JC}$				0.6				$^\circ\text{C/W}$
Operating junction temperature range	T_J				-55 to +150				$^\circ\text{C}$
storage temperature range	T_{STG}				-55 to +150				$^\circ\text{C}$

NOTES: 1. Measured at 1.0MHz and applied reverse voltage of 4.0V DC.

2. Device mounted on 300mm*300mm*1.6mm cu plate heatsink.

3. The typical data above is for reference only.

Ratings And Characteristic Curves

FIG.1-FORWARD CURRENT DERATING CURVE

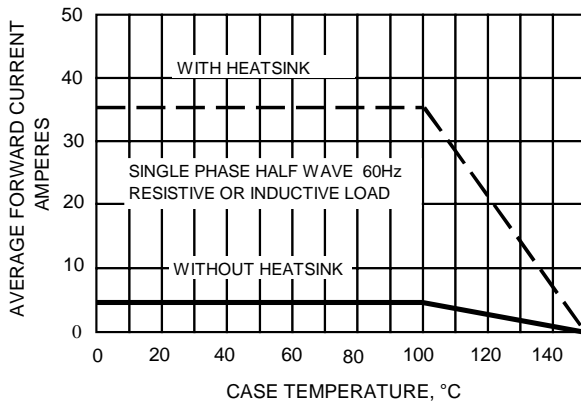

FIG.2-MAXMUN NON-REPETITIVE SURGE CURRENT

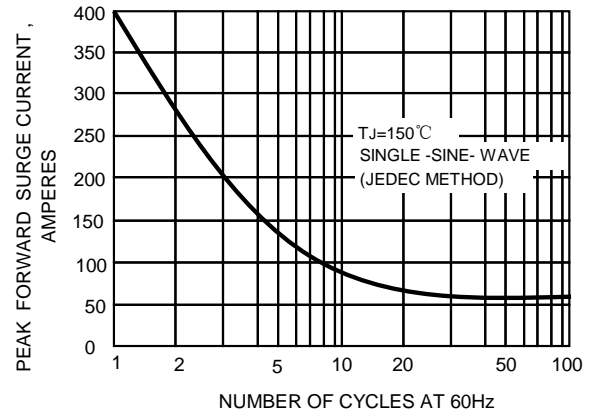

FIG.3-TYPICAL REVERSE CHARACTERISTICS

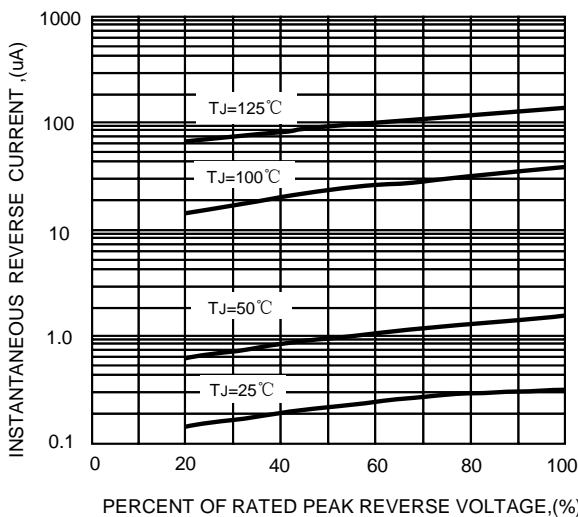
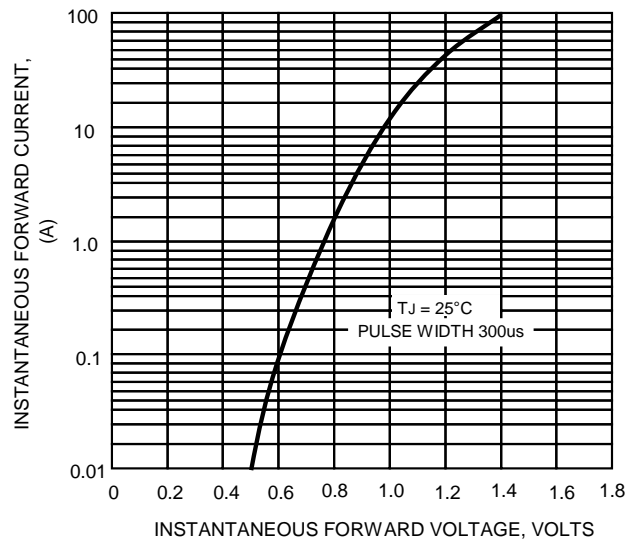

FIG.4-TYPICAL FORWARD CHARACTERISTICS



Important Notice and Disclaimer

Microdiode Electronics (Shenzhen) reserves the right to make changes to this document and its products and specifications at any time without notice. Customers should obtain and confirm the latest product information and specifications before final design, purchase or use.

Microdiode Electronics (Shenzhen) makes no warranty, representation or guarantee regarding the suitability of its products for any particular purpose, not does Microdiode Electronics (Shenzhen) assume any liability for application assistance or customer product design. Microdiode Electronics (Shenzhen) does not warrant or accept any liability with products which are purchased or used for any unintended or unauthorized application.

No license is granted by implication or otherwise under any intellectual property rights of Microdiode Electronics (Shenzhen).

Microdiode Electronics (Shenzhen) products are not authorized for use as critical components in life support devices or systems without express written approval of Microdiode Electronics (Shenzhen).

The curve above is for reference only.